

SPECIFICATIONS

General Information

- Easy-to-assemble sections allow for a simple and quick installation
- Hard roof tiles allow for use under wet sprinkler systems (check with local fire marshal)
- Tiles are class A fire rated, tested per ASTM E84
- Tiles are UL Listed- File R4036, and FM Approved-Class 4651
- Solid aluminum frame construction
- Supports custom aisle widths
- Modular design allows for any aisle length
- Fully supported by racks to leave aisle clear

Weight

- 3.17 kg/m² (0.65 lb/ft²)

Dimensions: Custom sizes available

- The use of structural aluminum extrusions allow for custom sizes to fit any application width and length
- Max height of 4cm (3")

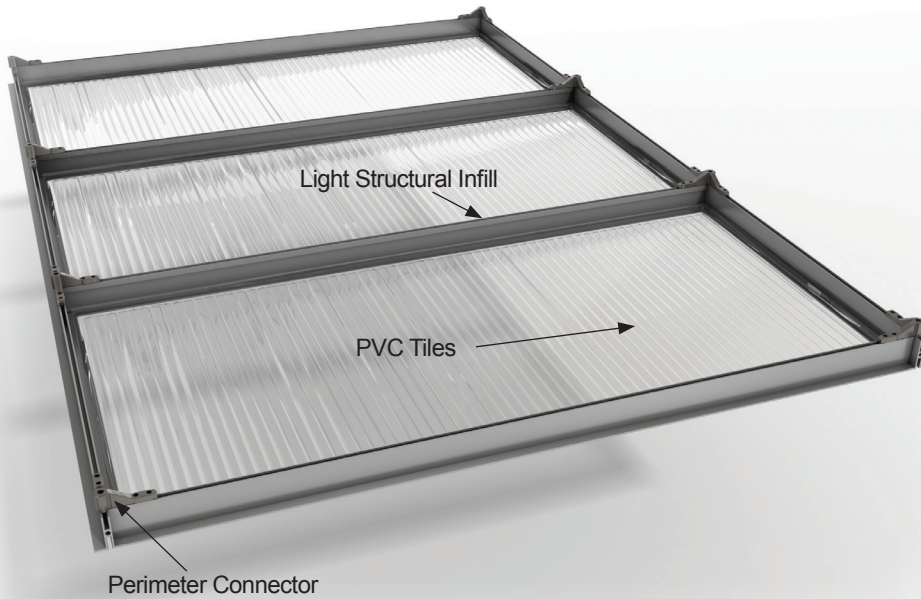

Spacer Bar with dual gaskets for proper sealing and fine length adjustment between adjacent roof sections

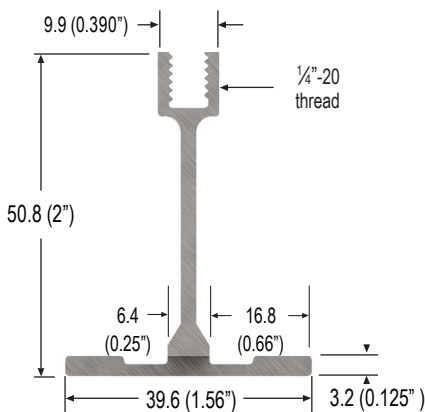

Light Structural Infill

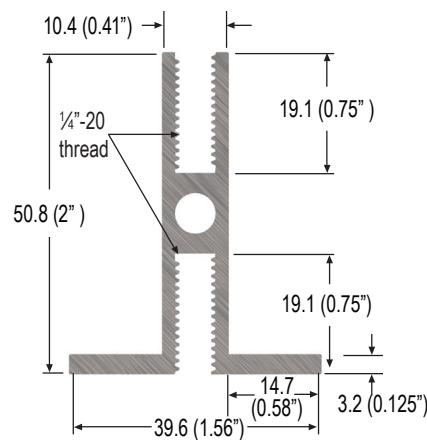

1/4"-20 Slot

Measurements in Inches (Millimeters)

INCLUDED COMPONENTS

- ContainAire® Hard Roof Frame
 - 1/4"-20 Extrusion
 - Light Structural Infill Extrusion
 - Perimeter Connectors
 - Field Connectors
- 3 Hard Roof Tiles per Frame Section
- Rack mounting hardware
- Installation guide

OPTIONS

Hard Roof Tile Options

- Clear
- Translucent

Aluminum Extrusion Finish Options

- Clear Anodized
- Black Anodized
- White Anodized

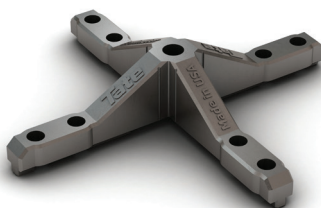

Perimeter Connector



Field Connector

HARD ROOF DIMENSIONS

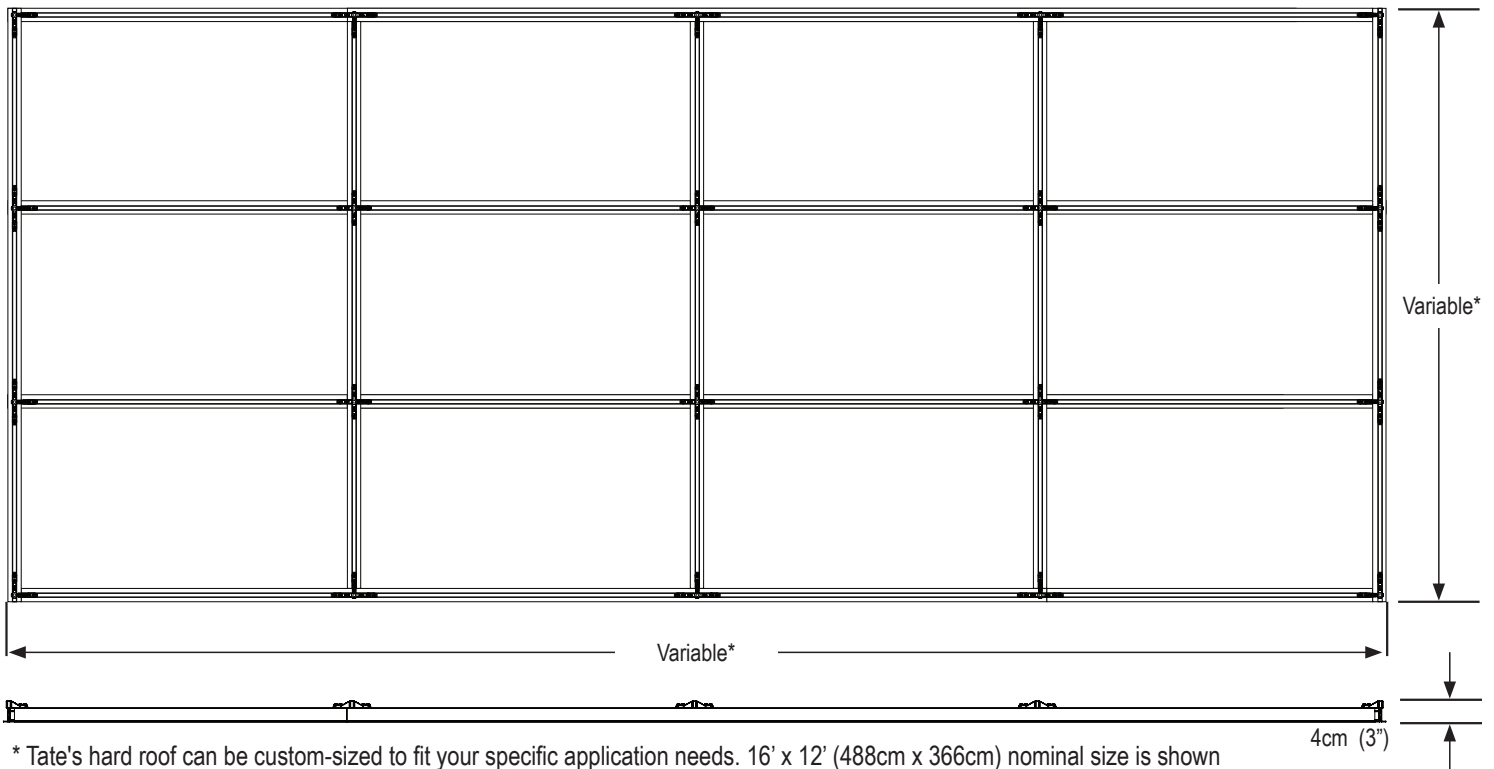

* Tate's hard roof can be custom-sized to fit your specific application needs. 16' x 12' (488cm x 366cm) nominal size is shown

FIELD CONNECTOR ASSEMBLY



Light Structural Main Runners notched to positively position connectors on center every time



Light Structural Infill coped for simplified installation and stronger connections

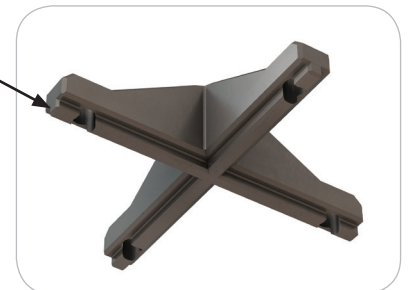
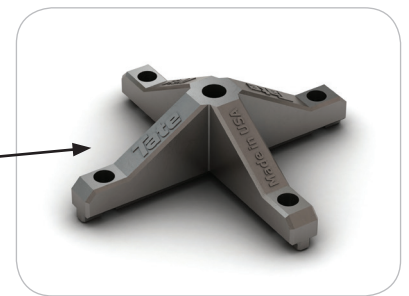

Ribs on connector to align with grid and prevent racking

PERIMETER CONNECTOR



Perimeter Connector can be cut on site to be used in various locations to connect grid together.

Bottom of Perimeter Connector is designed with ribs that locate the connector on Perimeter Extrusion.

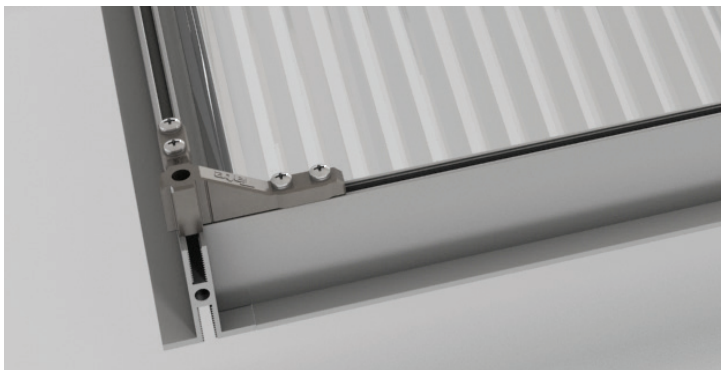

Perimeter Connector connecting 1/4\"/>



Perimeter Connector connecting 1/4\"/>

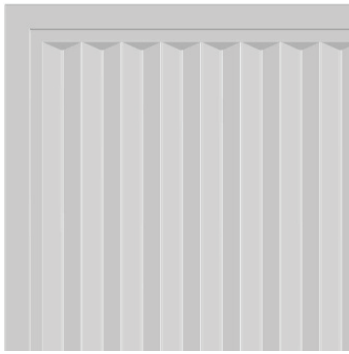

Translucent Tile

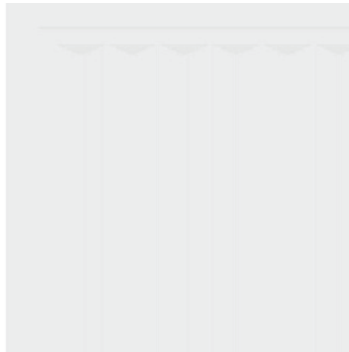

Clear Tile

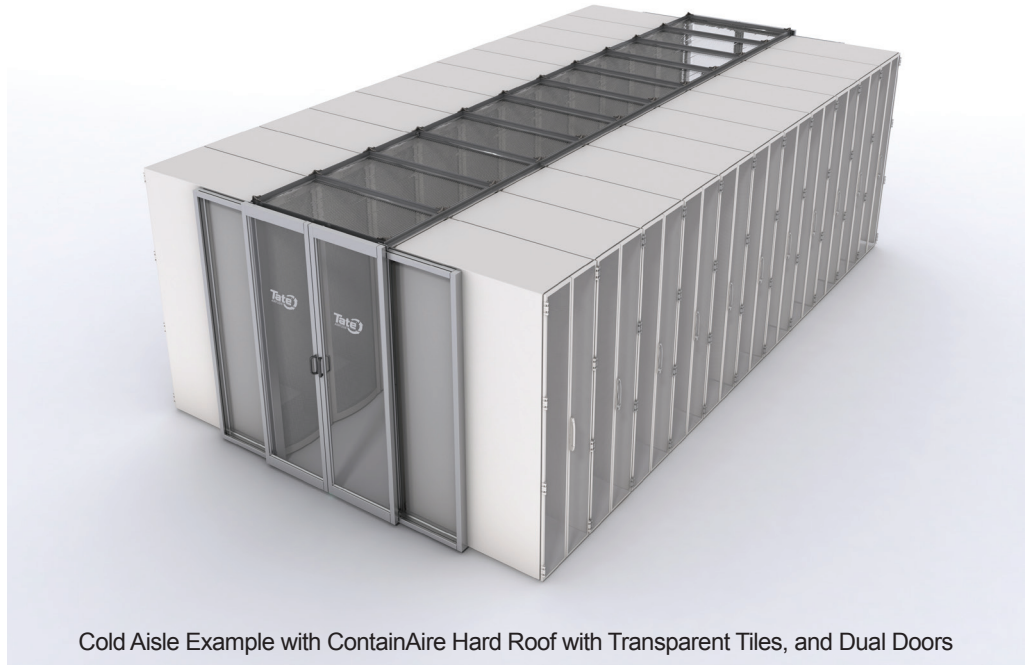

Cold Aisle Example with ContainAire Hard Roof with Transparent Tiles, and Dual Doors

PART NUMBERS

